



AUTOCOLLIMATORS
6B-LED/6D-LED

An extremely accurate metrology instrument for angularity, parallelism, flatness, and many other applications.

Features

- 6B-LED and 6D-LED both employ 70 mm aperture lenses to produce clear reflected images.
- Both give readings of angular displacement to 0.5 seconds of arc using an easy-to-read large-diameter micrometer drum.

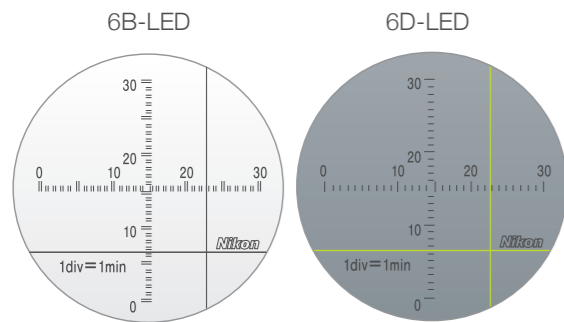

Field of Views

The 6B-LED has a bright field of view in which a black cross-hair image is visible. The 6D-LED has a dark field of view in which a bright cross-hair image is visible.

Example of Use

Pitch and Yaw accuracy of linear stage

The rotational accuracy (pitch and yaw) of the linear stage is measured by the reading the crosshair image as the stage with the plane mirror moves.

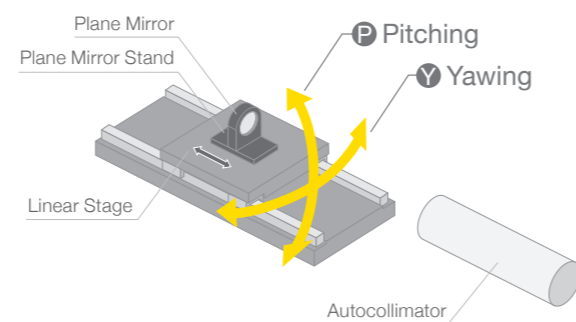

Specifications

Telescope magnification	38 x
Objective	f= 700 mm; effective aperture: 70 mm
Measuring range	30 minutes of arc (both vertical and horizontal axes)
Minimum reading	0.5 seconds of arc
Readout system	Adjustment in viewfield and reading on micrometer
Measuring accuracy	0.5 seconds of arc within a range of 5 minutes of arc 1 second of arc within a range of 30 minutes of arc
Viewfield	6B-LED: brightfield, 6D-LED: darkfield
Light source	LED
Power supply	12V 5A (AC adapter is required) or size AA battery x2
Dimensions of main body	Outer diameter of lens barrel support: 68 mm Overall length: Approx. 490 mm
Weight (including stand)	Approx. 32 kg

Dimensions

Unit: mm

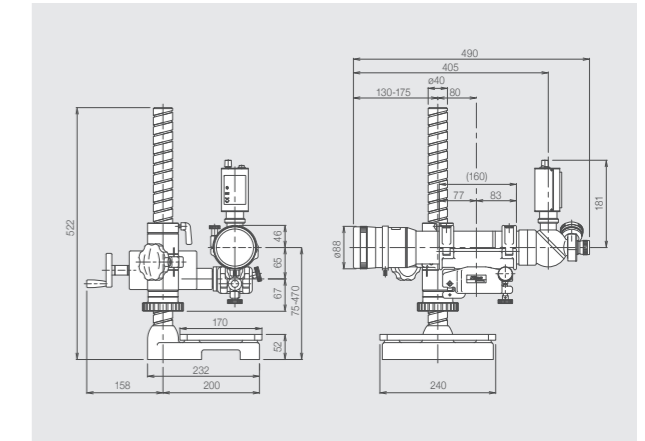

*Adjustable Stand Type C is sold separately

Accessories



Plane Mirror B

Highly accurate large reflecting mirror with permanent magnet. Convenient for fastening to iron-based materials.

- Effective aperture of reflecting surface (both sides): 70 mm
- Distance between legs of mirror stand: 100 mm
- Permanent magnet: removable, provided with on/off knob
- Wooden case provided



Plane Mirror D

General purpose reflecting mirror. The base and sides of the stand can act as guides for measuring straightness and flatness.

- Effective aperture of reflecting surface: 42 mm
- Distance between legs of mirror stand: 100 mm
- Wooden case provided



Plane Mirror C

Highly accurate large reflecting mirror with permanent magnet. Convenient for fastening to metal-based materials.

- Outer diameter: 30 mm
- Thickness: 12 mm
- Parallelism: 2 seconds of arc
- Wooden case provided



8-sided Polygon Mirror

Precisely divides 360° into 8 equal parts and can be used to measure index tables and rotating tables.

- Guaranteed accuracy: 1 second of arc for compensated values
- Outer diameter: 117 mm
- Diameter of center hole: 20 mm
- Thickness: 46 mm
- Wooden case provided



12-sided Polygon Mirror

Precisely divides 360° into 12 equal parts and can be used to measure index tables and rotating tables.

- Guaranteed accuracy: 1 second of arc for compensated values
- Outer diameter: 117 mm
- Diameter of center hole: 20 mm
- Thickness: 46 mm
- Wooden case provided

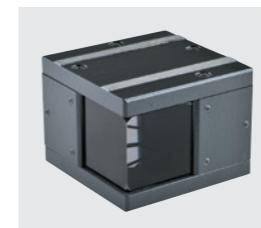

Pentaprism

Used as the standard (optical square) when measuring the squareness of two surfaces.

- Guaranteed accuracy (optical right angle): 2 seconds of arc
- Dimensions: 65 x 65 x 45 mm
- Metal frame and wooden case provided



Case for Autocollimators

Aluminum storage case for 6B-LED/6D-LED.



LED Illuminator AC-L1 for Autocollimators

6B-LED/6B-LED includes AC-L1 as standard feature. AC-L1 is the LED illumination unit used to retrofit the old 6B/6D to LED illumination.

- Power source: AA batteries x2, AC adaptor



C-mount TV adapter for Autocollimators

When used with the eyepiece tube, a C-mount TV camera can be attached to 6B-LED/6D-LED.

*The field of view of the monitor screen is narrower than that of the eyepiece. (Measuring range: 20 minutes of arc with a 2/3-inch CCD)

Other Examples of Use

Check the deflection of elastic or springy materials

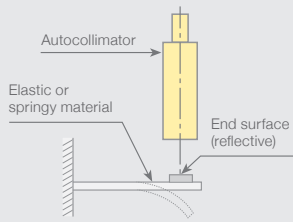

Affix the mirror the specimen and read the angular deflection using the autocollimator. Small vibrations may also be detected in this manner.

Check the parallelism of end surfaces

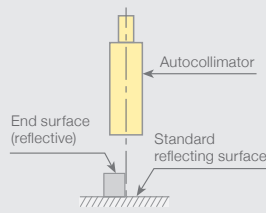

Compare the difference between the crosshair images reflected from the surface of the specimen and from a standard surface.

Check the angle of work pieces

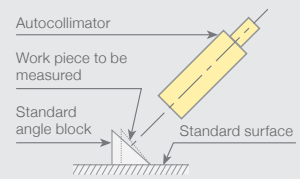

Measure the difference between the crosshair images reflected from the end surface of the work piece and from a standard angle block.

Check the squareness of rectangular pieces

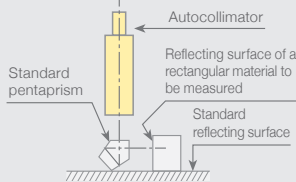

Compare the reading difference between the standard reflecting surface and the surface of the specimen using the Pentaprism.

Check the angular accuracy of rotary tables

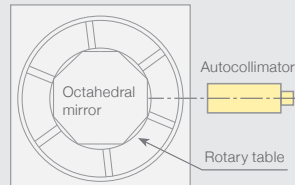

Measure the accuracy of rotary tables or dividing heads using polygon mirrors. The octahedral mirror measures in units of 45° , and the dodecahedral mirror in units of 30° .

Check the squareness of surfaces

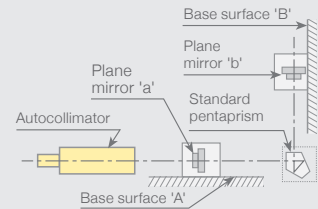

Compare the readings taken from plane mirror 'a' on surface 'A' to those from plane mirror 'b' on surface 'B' through the Pentaprism.

Specifications and equipment are subject to change without any notice or obligation on the part of the manufacturer. May 2026 ©2008-2026 NIKON CORPORATION

N.B. Export of the products* in this catalog is controlled under the Japanese Foreign Exchange and Foreign Trade Law. Appropriate export procedures shall be required in case of export from Japan.

*Products: Hardware and its technical information (including software)



WARNING

TO ENSURE CORRECT USAGE, READ THE CORRESPONDING MANUALS CAREFULLY BEFORE USING THE EQUIPMENT.



NIKON CORPORATION

1-5-20, Nishi-1, Shinagawa-ku, Tokyo 140-8601, Japan

Tel: +81 3 6743 5742

<https://industry.nikon.com/>

ISO 14001 Certified
for NIKON CORPORATION

NIKON METROLOGY EUROPE NV

Interleuvenlaan 86, 3001 Leuven, Belgium

Tel: +32 16 74 01 01

Sales.NM@nikon.com

NIKON METROLOGY UK LTD.

UNITED KINGDOM Tel: +44 1332 811 349

Sales.UK.NM@nikon.com

NIKON METROLOGY SARL

FRANCE Tel: +33 1-60 86 09 76

Sales.France.NM@nikon.com

NIKON METROLOGY GMBH

GERMANY Tel: +49 211 4544 6951

Sales.Germany.NM@nikon.com

NIKON METROLOGY, INC.

12701 Grand River Road, Brighton, MI 48116 U.S.A.

Tel: +1 810 220 4360

Sales.NM-US@nikon.com

NIKON METROLOGY - MEXICO

Sales.NM-US@nikon.com

NIKON PRECISION (SHANGHAI) CO., LTD.

CHINA Tel: +86 21 6841 2050 (Shanghai)

CHINA Tel: +86 10 5831 2028 (Beijing branch)

CHINA Tel: +86 20 3882 0551 (Guangzhou branch)

Web.Nis@nikon.com

NIKON INSTRUMENTS KOREA CO., LTD.

KOREA Tel: +82 2 6288 1900

NIK.Sales@nikon.com

NIKON SINGAPORE PTE LTD.

SINGAPORE Tel: +65 6559 3651

NSG.Industrial-sales@nikon.com

PT. NIKON INDONESIA

INDONESIA Tel: +62 213 873 5005

PTN.Instruments@nikon.com

NIKON SALES (THAILAND) CO., LTD.

THAILAND Tel: +66 2633 5100

NST.Inst@nikon.com

IM-AC2605EN

En