



VMZ-S SERIES



Video Measuring System

NEXIV

Standard Model

NEXIV VMZ-S Series

High Accuracy / High Speed / High Usability
Tolerance management at micro level.

High accuracy, high speed dimensional measurement with Nikon's technology. For decades the NEXIV series has met the demands of rigorous quality control departments in numerous industrial fields around the world. The NEXIV VMZ-S series can be used to measure various samples in the expanding market of in-vehicle electronic components and semiconductors, as well as in precision machined and molded parts. Capable of high accuracy and high-speed measuring for ever-growing sophisticated demands, the series can also be used in a wide range of applications.

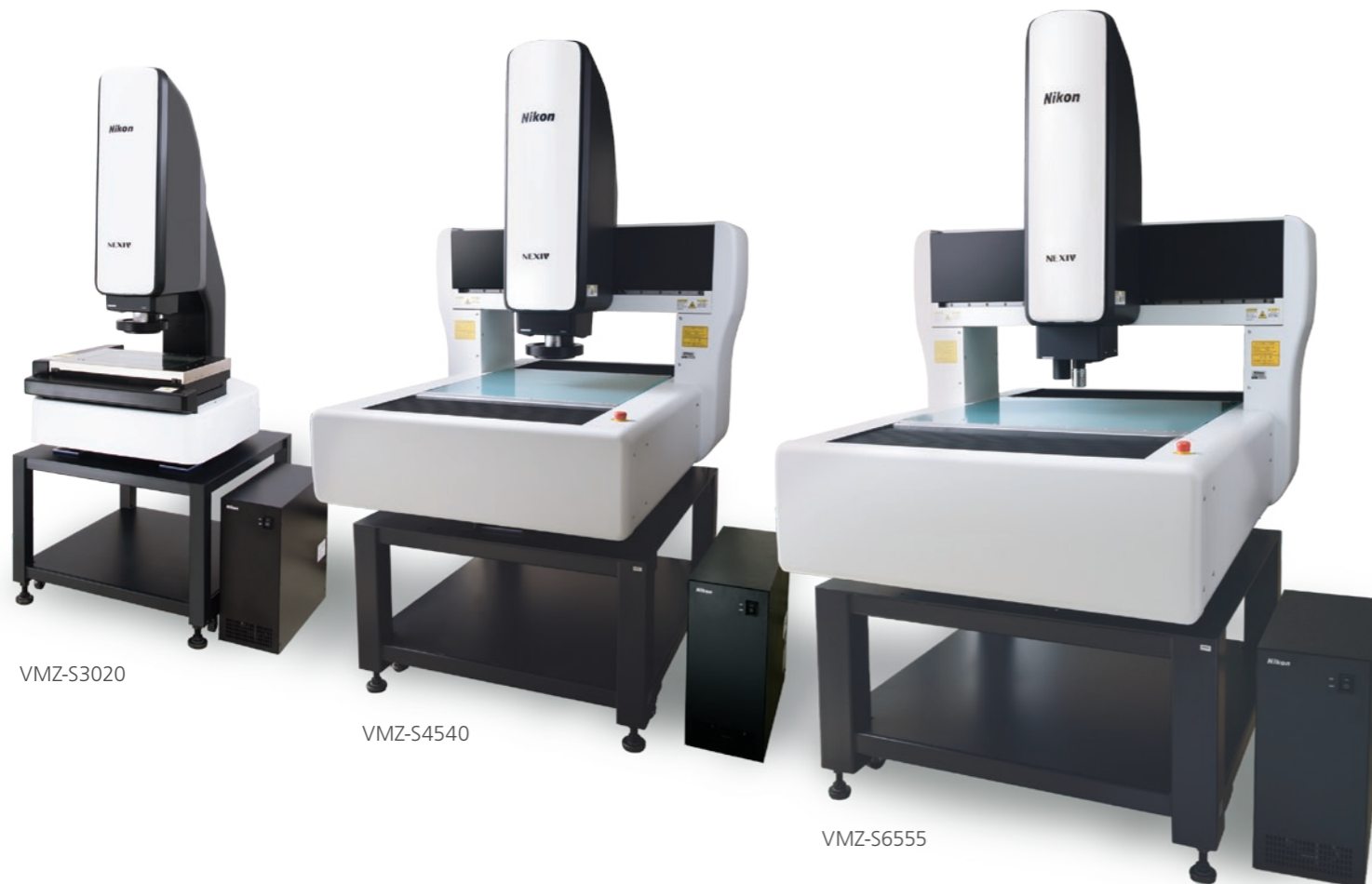

Challenges with Dimensional Measurement with Current Inspection Tools

Measurement Microscope

Profile Projector

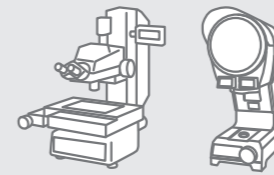

- Need to improve work efficiency as there are many measurement samples.
- Different measurement results as there are variations in technician subjectivity and experience.

Competitive Video Measuring Systems

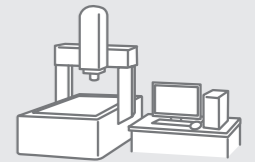

- Measuring accuracy not stable.
- Poor performance measuring Z heights.
- Some samples cannot be measured.
- Poor performance due to part variations or misalignment.

Using the NEXIV VMZ-S Series

Significantly improved measurement efficiency

Many samples can be measured with program measuring that utilizes image processing and high-performance electric motor stages.



4.2 hours



0.6 hour

86% less measurement time

*Dimension measurement time for multiple measurement points of 100 samples (100 mm x 100 mm) are compared with Nikon's measurement microscope and VMZ-S6555 (30 samples measured at once). The measurement time for VMZ-S6555 includes measurement program creation time.

Eliminate operator measurement variations

Able to achieve highly repeatable measurement independent of operator subjectivity and experience.

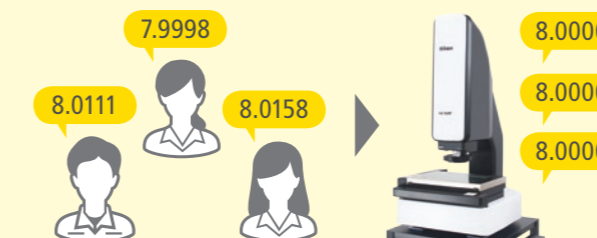

Stable measurements with high accuracy

Steady, high accuracy measurements can be obtained through a system designed and optimized from the ground up matched with a specially designed Nikon optical system for accurate measurements.

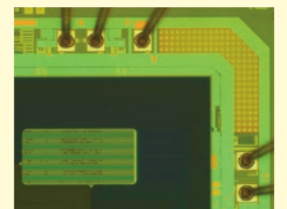

CMOS image sensors
(Optical magnification 4x, Total magnification 144x)

High accuracy, high speed height measurement

Highly accurate, high speed height measurements made possible with the high accuracy TTL laser AF capable of high-speed scanning at 1000 points per second.

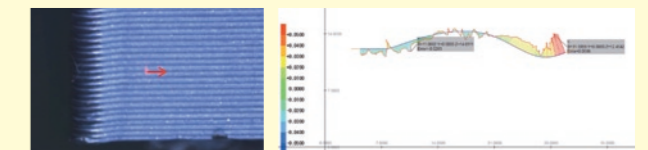

Possible to measure difficult samples

Difficult edges and features can be detected with multiple illuminations.



Non-stop automatic measuring

Accurate measurement can be achieved despite variation of component positioning.



High accuracy, high speed dimensional measurement

A dedicated optical system made possible only with Nikon manufactured optics. Achieve accurate and stable measurement results quickly with Nikon's high-specification hardware design and control technologies. This has been built up over many years, meeting the demands of the manufacturing industry where high quality is paramount.

Dedicated optics making highly accurate and highly efficient dimensional measurements possible

Capable of high resolutions at long working distance

Microsamples that require measurement at high magnification can also be taken in clear, bright images with specially designed high-NA (numerical aperture) lenses. At the same time, it is possible to measure various samples that differ significantly in height as a long working distance is guaranteed.

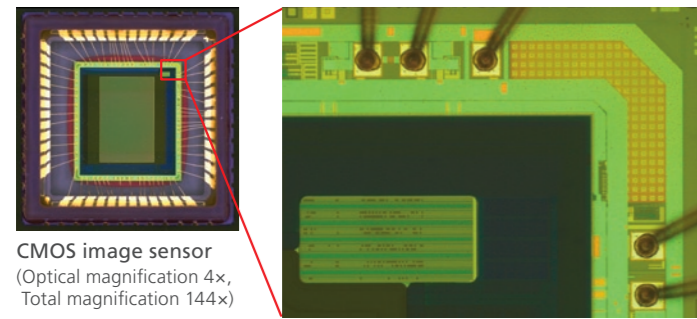

CMOS image sensor
(Optical magnification 4x,
Total magnification 144x)

Zooming heads	Optical magnification	Working Distance
Type 1	0.5 – 7.5x	50 mm
Type 2	1 – 15x	
Type 3	2 – 30x	
Type 4	4 – 60x	
Type TZ	1 – 120x	(High-mag.) 11 mm / (Low-mag.) 31 mm
Type A	0.35 – 3.5x	73.5 mm (63 mm with Laser AF)

Wide ranging zoom optics streamline dimensional measurements

Offers a 15:1 zoom range which is achieved without the need to swap objective lenses. (Type 1-4 heads). This allows the easy location and alignment of features prior to measurement at high magnification.

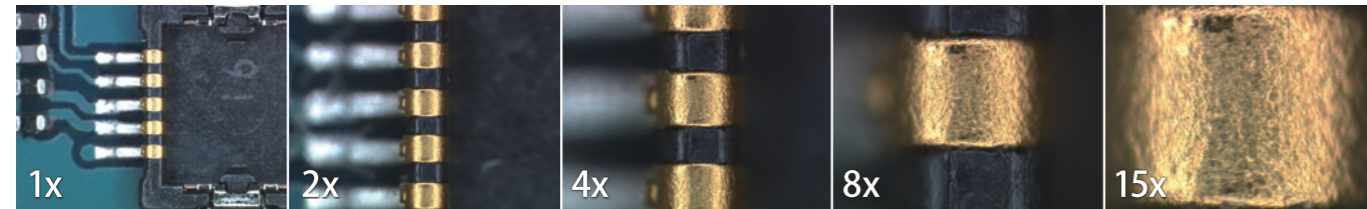

Type2 head (1x~15x)

Equipped with five zoom positions that do not require calibration when magnification is changed (Type TZ has 8). Efficient program creation and dimensional measurement are achieved as magnification can be changed at high speed, whilst maintaining highly accurate measurement.

Excellent accuracy within field of view

Highly reliable measurement results can be obtained throughout the field of view because of the special lenses optimized for dimensional measurement with low distortion.

Probing error*	P _{F2D} 0.8 μm
----------------	-------------------------

* Type2 zooming head. Determined by Nikon in-house measurement method. Measurement of the perimeter of circular reference device. It involves stage movement which caliper within the FOV is evenly placed at 25 points on the perimeter.

Probing error of the imaging probe*	P _{FV2D} 0.3 μm
-------------------------------------	--------------------------

* Type2 zooming head. Determined by Nikon in-house measurement method. Measurement of 25 points that are evenly placed on the perimeter of circular reference device at one location on the screen (without stage movement).

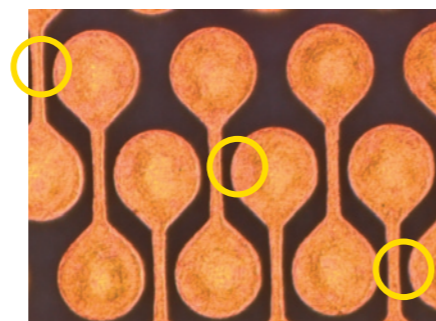

Micro wiring patterns
(Type2 head, optical magnification 15x)

High reliability within the FOV.

High accuracy, high speed measurement with through the lens (TTL) laser AF

Through the lens (TTL) spot, scanning laser is standard on the VMZ S models. Achieves high measurement reproducibility in the Z direction ($2\sigma \leq 0.5 \mu\text{m}$).

Accurately detects small changes in height variations. Operates independent of magnification or illumination same performance throughout zoom range. Can also obtain sample cross-sections with the high-speed laser scan at 1,000 points per second.

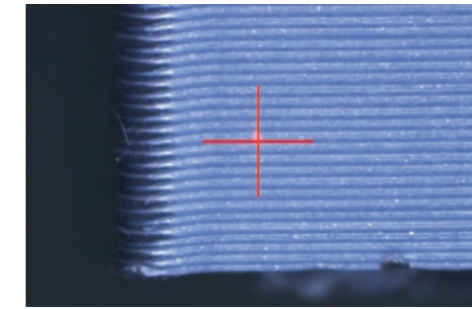

Laser spots can be checked by darkfield illumination

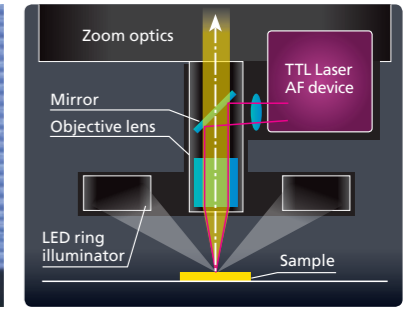

TTL Laser and AF schematic

Image AF for any number of uses

Image AF, which detects height from an image of the shape and texture of the sample's surface, not only matches points on the sample's surface and contour edges but also measures height and depth. High-speed and high accuracy even in samples with height variations or chamfers.

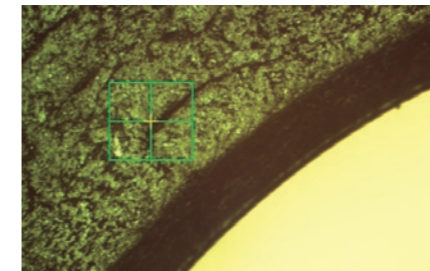

• **Surface mode**
Focus on surface of objects

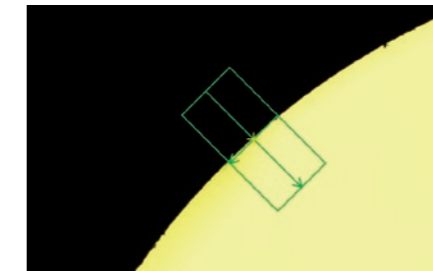

• **Contrast mode**
Focus on edges contoured by the bottom light

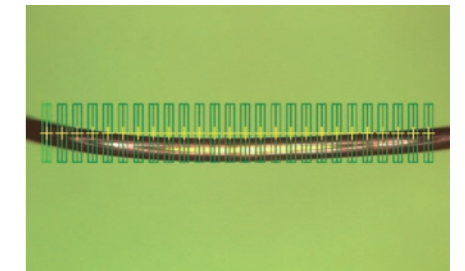

• **Multi mode**
Measure height of multiple points in the FOV

Robust system design optimized for high accuracy and high-speed dimensional measurement

Hardware structure that achieves stable measurements with high accuracy

A material close to that of the coefficient of thermal expansion is used in the guide rail of the main unit and measurement stage. This ensures there is little change in shape to the guide rail even with environmental temperature changes, minimizing any impact on changes to accuracy.

Nikon's proprietary linear encoder boasting the highest level of resolutions in video measuring system

Nikon's proprietary linear encoders with 0.01 μm resolution, are built as standard into all axes to accurately detect linear position, providing stable measurement results with high accuracy.

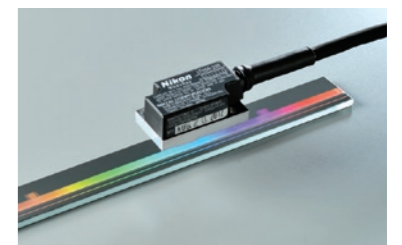

Improved system throughput

Nikon has achieved high-speed measurements, faster than conventional systems, through its pursuit of control technologies and stages capable of operating with high accuracy. Cycle time has been greatly reduced with the continuous automatic measurement of microsamples, such as semiconductor and electronic components, accompanying numerous short-range movements.

Conventional NEXIV (VMZ-R3020)	182 sec.	34% less Measurement time
VMZ-S3020	120 sec.	

* Measurement of 625 (25x25) circle diameter. $\phi 50 \mu\text{m}$, Pitch: X,Y=0.2 mm, Stage speed: max, FOV: 0.58x0.44 mm. Same teaching file is used for measurement.

Stable automatic measurements for various samples.

The VMZ-S series incorporates a large number of functions that are essential for carrying out continuous automatic measurements.

Lighting systems capable of reliably detecting all shapes

Standard heads are equipped with episcopic, diascopic, and 8-segment LED ring illumination. Edges can be properly detected with any combination of lighting and light quantity even in samples with hard to detect height variations or chamfers, allowing for reliable automatic measurements.

Light settings: 015, 015, 015

37° W.D.: 50mm • LED inner ring light

55° W.D.: 36mm • LED outer ring light at 55 degree position

78° W.D.: 10mm • LED outer ring light at 78 degree position

Cross-section

37° 55° 78°

Detects difficult shapes with epi-illumination

Easily detects obscure edges at the standard angle of incidence (37°)

Robust edge selection function to detect random edges

One edge from a choice of many can be selected and detected. More accurate and reliable automatic measurements can be obtained by rejecting mistaken edges brought about by foreign matter on the sample's surface.

Detect proper edges by rejecting burr effects

Search function to compensate for misalignment and sample variations

By automatically detecting and correcting misalignments created from how samples are placed and variations in manufacture, smooth continuous automatic measurement are made possible, even when measuring multiple samples at once.

Recorded image

1 Target is detected

2 Searching the misaligned target

3 Target is detected

Samples in various locations can also be automatically detected.

XY coordinate

XY coordinate after searching the target

Six types of optical heads with 15x zoom capability for many different measurement needs

5 zoom positions (Type TZ has 8) in one head. Meeting the measurement requirements for accuracy and size in a wide range of samples.

Standard magnification zooming heads (type 1-3)

Connector, IC package, PCB, MLCC, Lead frame, Camera Module, Glass and Plastic Lenses, etc.

Printed circuit board (optical magnification 1x) Type 1 / 8 segment LED ring light

Printed circuit board (optical magnification 2x) Type 2 / 8 segment LED ring light

High density PCB (optical magnification 1x) Type 2 / coaxial top light

Zooming heads		Minimum measurement diameter (as a guide)*
Standard magnification	Type 1	221 – 15 μm
	Type 2	111 – 8 μm
	Type 3	56 – 4 μm

High magnification zooming heads (type 4 / type TZ)

High density printed circuit board, fine semiconductor package, Micro Electro Mechanical (MEMS) parts, etc.

High density PCB (optical magnification 16x) Type 4 / coaxial top light

IC chip (optical magnification 8x) Type 4 / coaxial top light

High density PCB (optical magnification 16x) Type TZ / dark field illumination

Zooming heads		Minimum measurement diameter (as a guide)*
High magnification	Type 4	34 – 2.2 μm
	Type TZ	111 – 0.9 μm

Wide FOV zooming head (type A)

Molded parts, Sheet metal stampings, rubber seals and parts, mechanical components, etc.

Plastic molded part (optical magnification 0.35x) Coaxial top light

Plastic molded part (optical magnification 0.6x) Coaxial top light

Resin parts (optical magnification 0.35x) 8 segment LED ring light

Zooming heads		Minimum measurement diameter (as a guide)*
Wide FOV	Type A	327 – 33 μm

*Minimum measurement diameter (as a guide): This is not a guaranteed value. Sample: Calibration plate. diascopic light and measurement within FOV (without stage move). Diameter is calculated by creating least-squares circle from 36 measurement points. Please use this as a guide when choosing head types.

Optical magnification	0.35	0.5	0.6	1	1.8	2	3.5	4	7.5	8	15	16	30	32	60	64	120
Type 1																	
Type 2																	
Type 3																	
Type 4																	
Type TZ																	
Type A																	
FOV size on stage	13.3	9.33	7.8	4.7	2.6	2.33	1.33	1.165	0.622	0.582	0.311	0.291	0.155	0.146	0.078	0.073	0.039
Horizontal (mm) x Vertical (mm)	10.0	7.01	5.8	3.5	1.9	1.75	1.00	0.875	0.467	0.437	0.233	0.218	0.117	0.109	0.058	0.055	0.029
Total magnification*	12.6	18	21.6	36	64.8	72	126	144	270	288	540	576	1080	1152	2160	2304	4320

* Total magnification is that of video window with 640 x 480 pixels on 24 inch WUXGA monitor (1920 x 1200 pixels).

3 models with different XY measuring envelopes

Choose the best model to suit sample size, sample quantity, and installation environment.

Standard stroke (300×200×200 mm)

VMZ-S3020

From machine parts and mold parts to high density printed circuit boards, VMZ-S3020 meets a wide variety of measurement needs.

Applications

- Type 1-3: Connectors, semiconductor packages, small PCB's, small stamped sheet metal parts, lead frames, watch components, etc.
- Type 4/TZ: High density PCB's, lead frames, semiconductor packages, MEMS, probe cards, etc.
- Type A: Plastic molded parts, sheet metal parts, rubber parts, mechanical parts, implant components, watch components, etc.

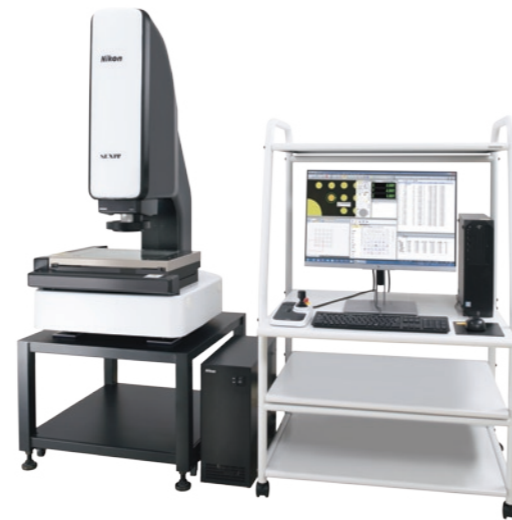

Middle stroke (450×400×200 mm)

VMZ-S4540

Perfect for various mold parts, medium-sized flat panels, and printed circuit boards. Measuring also possible using various jigs and mechanical components with height.

Applications

- Type 1-3: Middle size PCB's, stamped sheet metal parts, etc.
- Type 4/TZ: 300 mm wafers, 300 mm probe cards, etc.
- Type A: Middle size mechanical parts, plastic molded parts, etc.

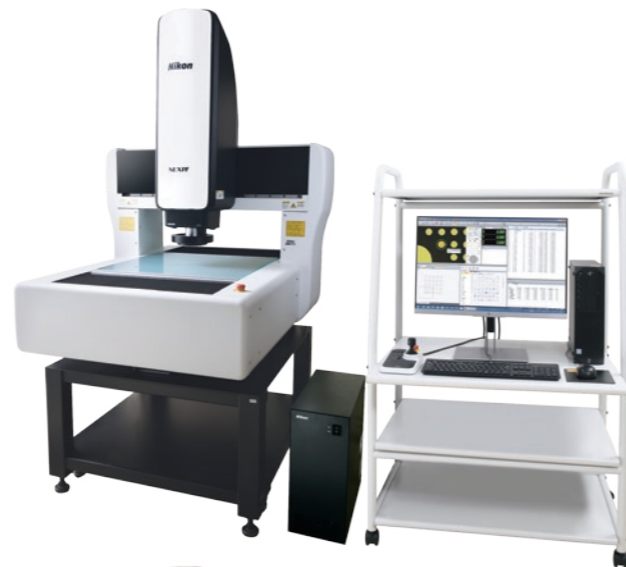

Large stroke (650×550×200 mm)

VMZ-S6555

VMZ-S6555 is perfectly adapted to large samples. At its best with accurate measurement of printed circuit boards and automatic measurement of a large number of small parts.

Applications

- Type 1-3: Large PCB's, large plastic molded parts, etc.
- Type 4/TZ: High density large PCB's, etc.
- Type A: Large stamped sheet metal parts, Large plastic molded parts, etc.



Easy to use, streamlined software suite

NEXIV AutoMeasure, dimensional measurement software for the ever-evolving NEXIV series. Support functions to create measurement programs have been further enhanced, making fast, highly accurate dimensional measurements easier than ever before.

Graphical user interface to efficiently create programs with intuitive operation and easy-to-understand guide

Measurement programs can be created by selecting the icon for edge detection and that which should be measured.

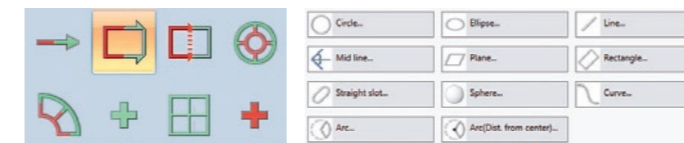

Edge detection and AF icon Various measurement icons

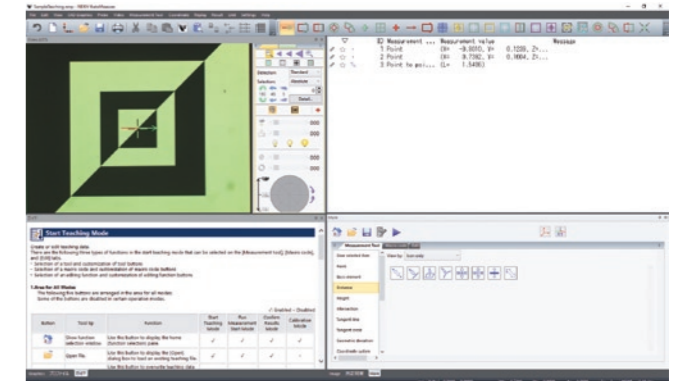

Automated edge setting function

Edge detection conditions are automatically set by simply selecting the target edge from the waveform profile. Even if multiple edge candidates are detected, the operator can specify the correct edge, improving the simplicity and efficiency of operation.

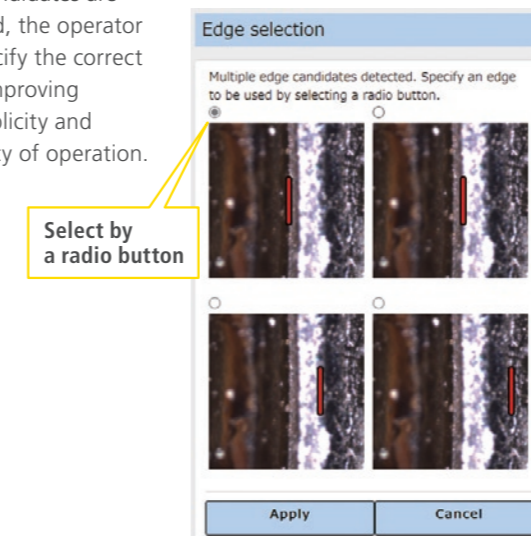

Select by a radio button

Teaching navigation

Simply follow the on-screen instructions and the required measurement settings are entered automatically. Even first-time users can create basic measurement programs.

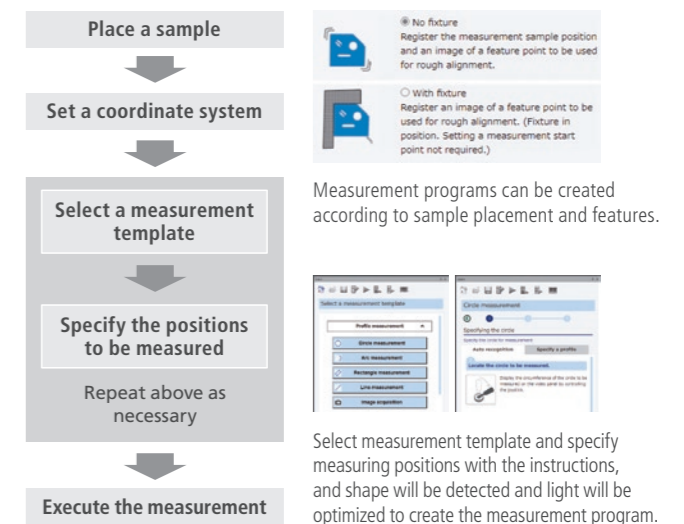

Lighting optimization function

Automatically optimizes the type of lighting, direction of ring illumination, and light intensity according to features of object measured. Makes it possible to reduce the amount of time and effort spent creating measurement programs.

*Optimizations may not be possible depending on shape of object measured.

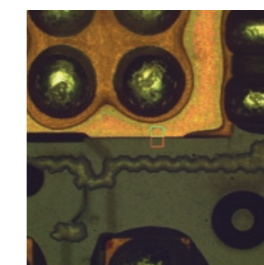

Result of lighting optimization, detecting edge of height variations in the patterned area of a PCB. (Optimization with epi-illumination)

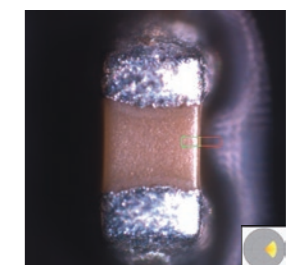

Result of lighting optimization, detecting edge of condenser component mounted on a PCB. (Optimization of light source direction and intensity with ring illumination)

Evaluation of shapes

Errors can be visualized by overlaying nominal and measured shapes. Can be used for both geometrical shapes and free-form shapes.

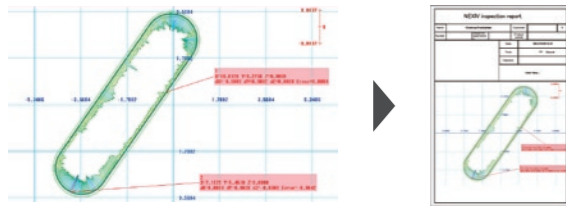

- Calculation of errors can be made in normal or axis direction
- Nominal shapes can be made from CAD data or XYZ coordinate values
- Measured shapes can be output as CSV or DXF files
- Evaluation reports can be made in PDF files

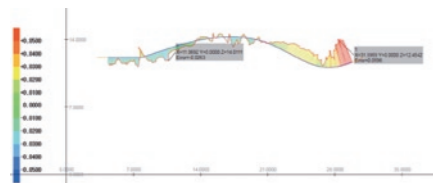

Able to obtain sample cross-sectional shapes with the high-speed laser scan at 1000 points per second. Compatible with shape evaluation in height direction.

Result evaluations in line with JIS/ISO standards

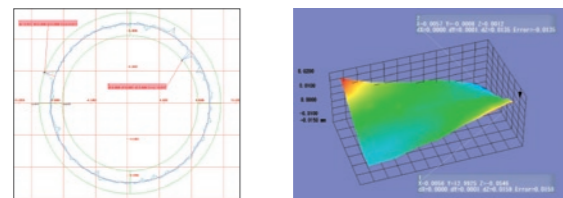

Circle (roundness)

Plane (flatness)

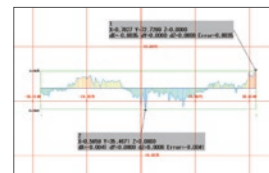

Line (straightness)

Geometrical tolerance measurements

Equipped with the ability to measure various geometrical tolerances.

Perpendicularity	Parallelism
True position	Roughness (ISO 1997)
Angularity	Concentricity
Symmetry	Circular runout

DXF file creation

DXF files can be created from measurement results.

Offline teaching

Computer-aided design (CAD) data can be used to create measurement programs for offline teaching before any sample is obtained. Working on a separate computer* to the NEXIV main unit frees it up so it can be used to full capacity.

*Dongle key required. Please contact Nikon for any offline teaching requests.

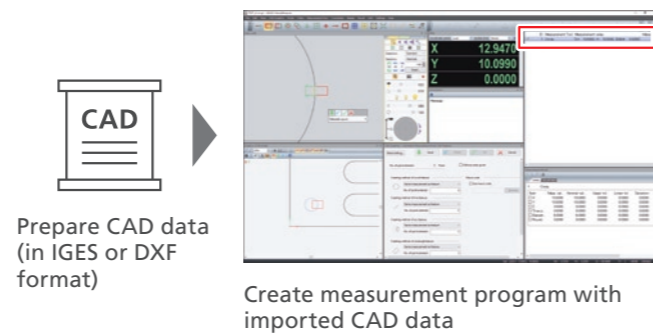

Digital operation guide NEXIV Note

The function offers slides and movie output together with NEXIV contents, such as basic operations and functions. Simple measurement programs can be created by referring to this application.

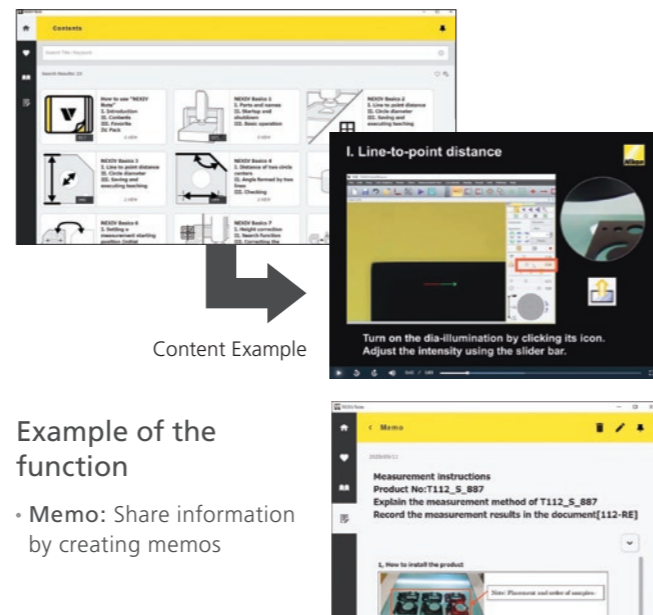

Example of the function

- Memo: Share information by creating memos

MapMeasure Pro

Easily specify any chip on the chip map with just a click of the mouse. Huge improvements in measuring efficiencies of standardly arranged samples, such as wafers.

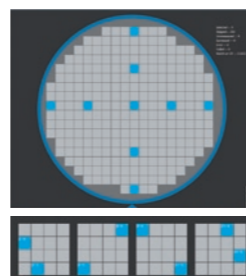

For the management of various evaluations and measurement results

From importing CAD data to the evaluation, management and utilization of measurement results, Nikon has a whole range of optional software solutions to improve productivity in dimensional measurements in any situation.

EDF/Stitching Express

Images taken with the VMZ-S can be stitched to get a larger mosaic image, while images at different heights can result with an image with Extended Depth of Focus (EDF). Stitching and EDF can produce full 3D graphics.

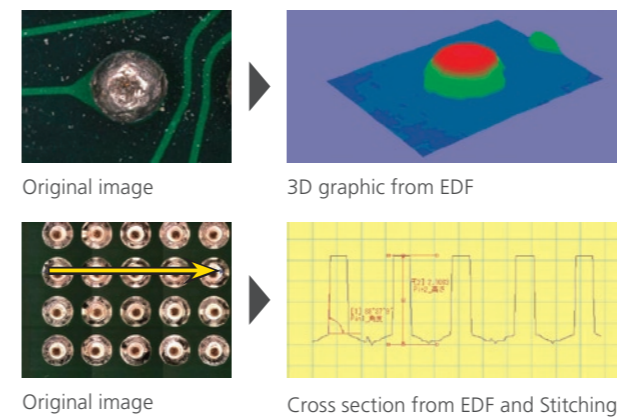

MountainsMap X®

Sample surfaces can be analyzed, based on ISO, with the data exported from VMZ-S.

Provided for Nikon by Digital Surf (France)

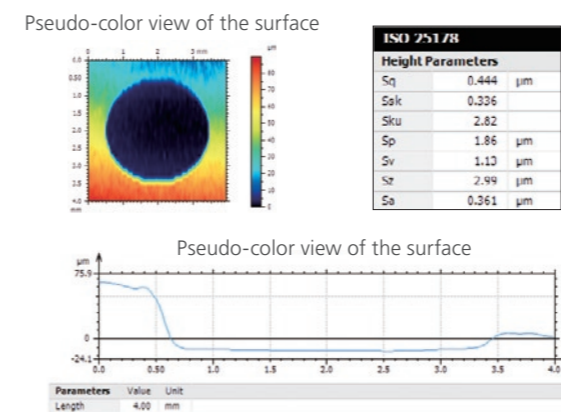

Inspection Results Preparing System

ImageFit QC

Inspection results used can be imported and automatically reflected into the measurement results. Pass/fail results and statistical data*1 are generated automatically. The function to create graphs*2 also helps visualize measurement results.

- *1: Standard deviation, process capability index (Cp, Cpk)
- *2: Line graphs, histograms



Custom Fit QC

Measurement results are read into 10 different templates and pass/fail results and calculation results*1 are automatically exported. Graphs*2, including \bar{X} -R control charts and scatter diagrams, can be automatically generated to visualize measurement results.

- *1: Average, maximum value, minimum value, range, standard deviation, and process capability index (Cp, Cpk)
- *2: Line graphs, histograms, \bar{X} -R control charts, scatter diagrams

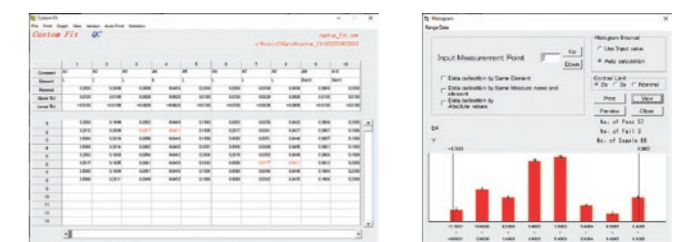

*Excel is required

Codeveloped by Aria Co., Ltd. (Japan)

3D CAD Converter

3DCAD model can be converted to 2DCAD (NCD) file, which can be used in NEXIV AutoMeasure.

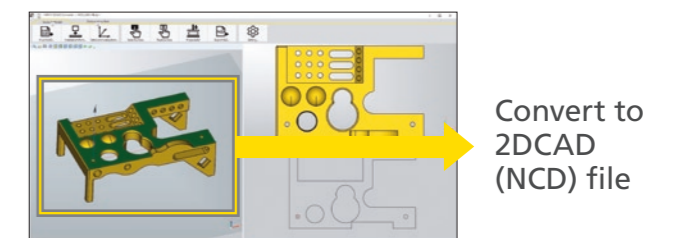

Automating the production floor

Helping to further automate and advance the production floor through multiple NEXIV controls and integration of component carrier conveyor systems.

Remote control SDK for automatic measurement system integration

The remote control Software Development Kit (SDK) is a tool for developing user software modules to control and automate the NEXIV video measuring systems. Automate component carriers and measurement steps remotely or on the production floor by integrating NEXIV together with the component carrier conveyor system.

Save manpower and automate the production floor

– Control multiple NEXIV systems remotely.



Manage measurement programs and results all in one place

– Transfer measurement programs to the NEXIV and collect measurement data results via secure network.

– Reduce errors by eliminating the need to go and collect measurement results from, or copy measurement programs to and from every NEXIV PC location.

Easily create control software routines to optimize factory operations

– A suite of tools makes it straight forward to build the routines.

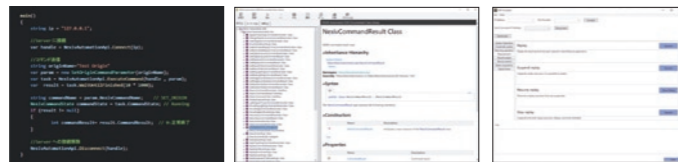

Sample of code

Reference summary

Sample application

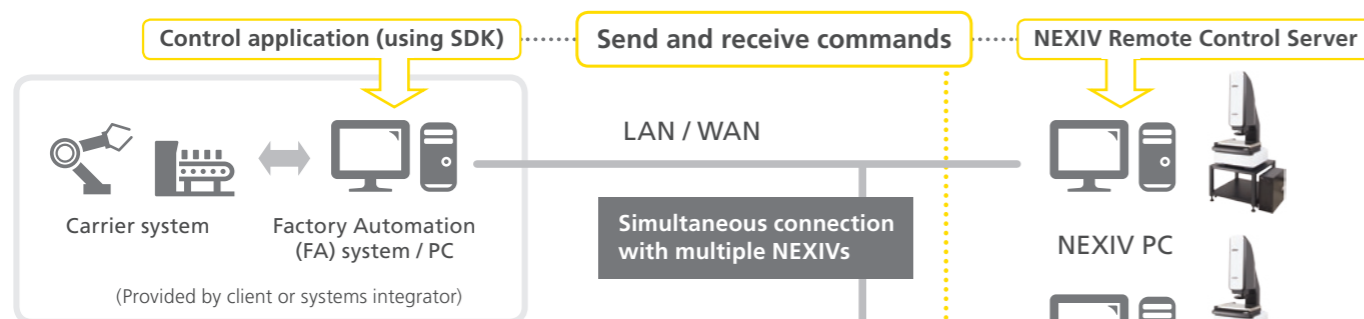

Illustrative example of "NEXIV" operation using "Remote Control SDK". Please take the appropriate safety measures when installing.

Dimension

VMZ-S3020

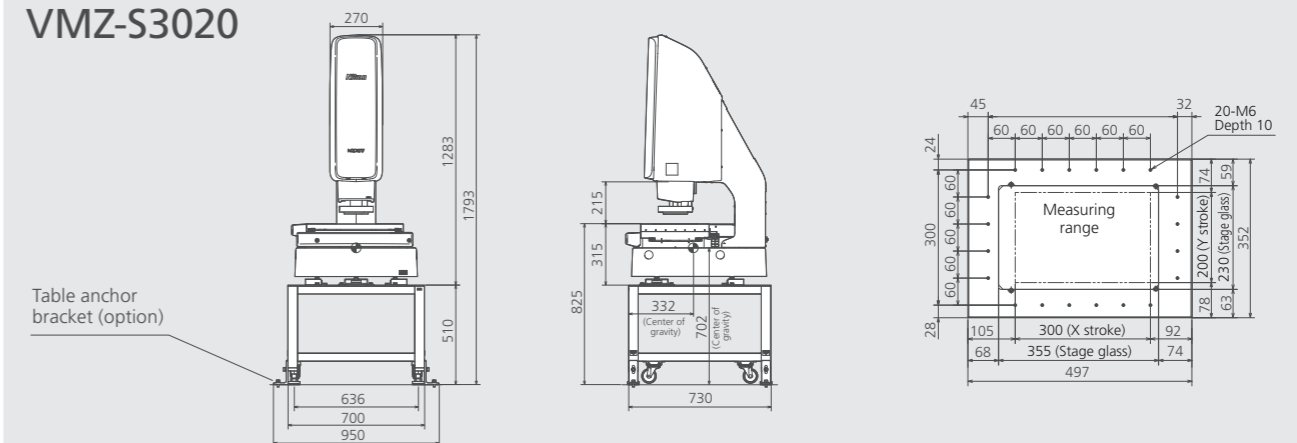

VMZ-S4540

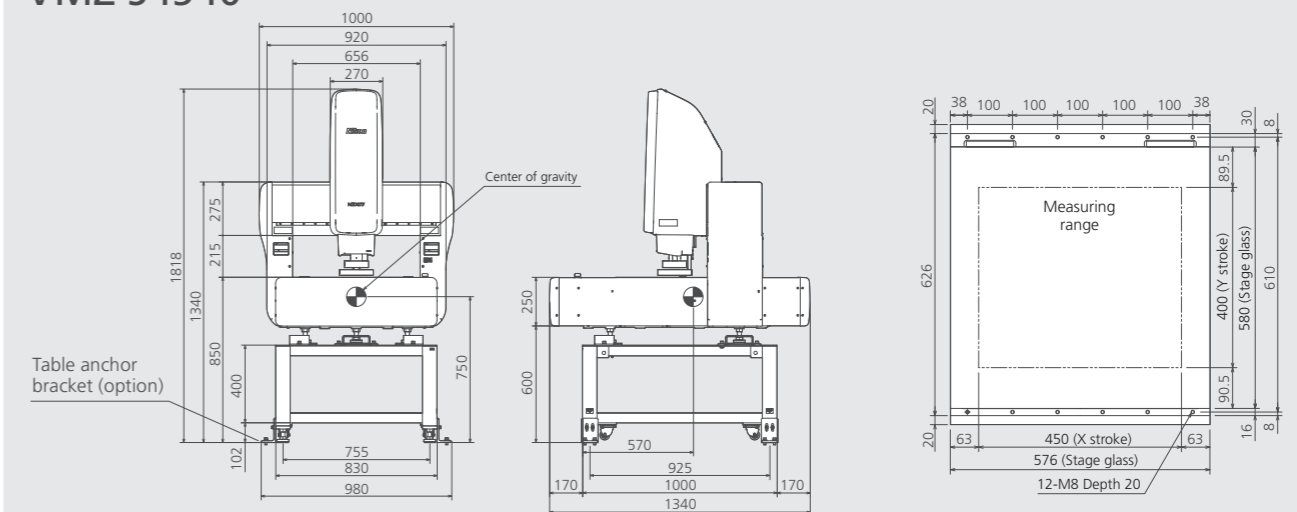

VMZ-S6555

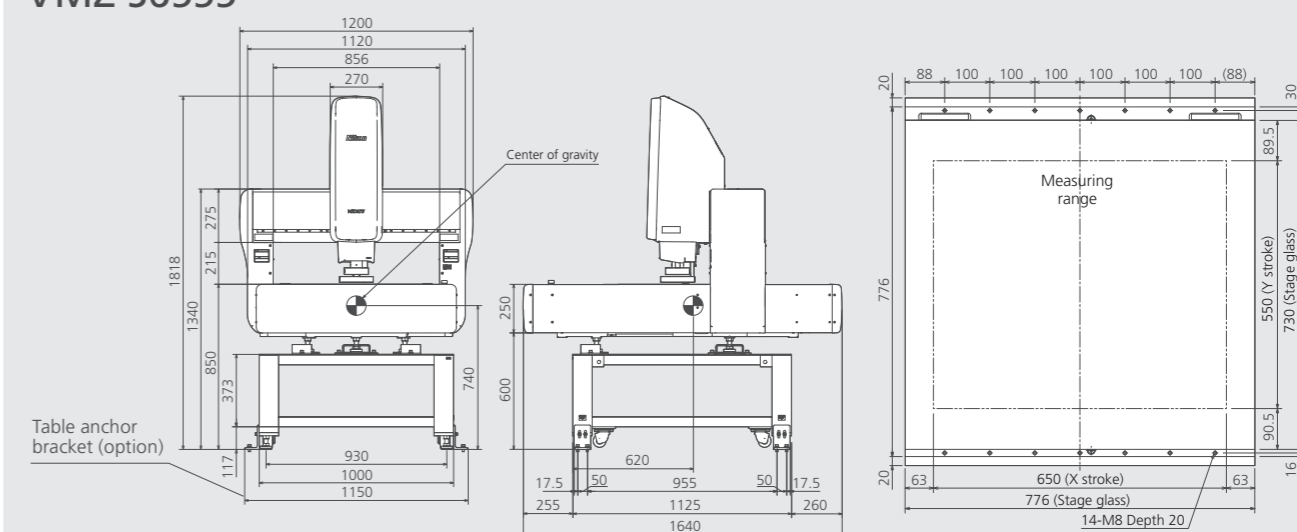

Various system variations in the NEXIV series

For more accurate measurements, for measurements with wider field of view, and for quick height measurements. All the various system variations in the NEXIV series meet the different measurement needs.

High accuracy model VMZ-H3030



VMZ-H3030

- **NEXIV series high accuracy model**

Easy-to-use, fast and the most accurate measurements in the NEXIV series with the accurate stage operation and high-performance optics.

Applications

Micro boards (line width, height), next-generation semiconductor packages (WLP, bump height), precision molds, rewiring masks, MEMS masks, etc.



Precision machine parts Precision machine parts Molds IC chips

Model	VMZ-H3030
XYZ strokes	300×300×150 mm
Maximum sample weight	30 kg (Accuracy guaranteed: 10 kg)
Maximum permissible error (L: Length in mm)	EUX, MPE: $0.6 + 2L / 1000 \mu\text{m}$ EUY, MPE: $0.6 + 2L / 1000 \mu\text{m}$ EUZ, MPE: $0.9 + L / 150 \mu\text{m}$

Wide FOV model VMA



iNEXIV VMA-4540

- **Up to 13.3 x 10 mm field of view (on stage 0.35x at observation)**

Easy to check measurement position and alignment of samples and stage

- **Long working distance of 73.5 mm**

At its best with depth measurements in large height variations, high bosses, and fine, deep holes, etc.

- **Compatible with touch probe measurements (optional)**

Able to measure the dimensions and angles of unseen parts, such as the bore of side holes.



Distance to focal plane
73.5 mm

Applications

Electronic parts, resin molding parts, various mold parts, press parts, die cast parts, etc.

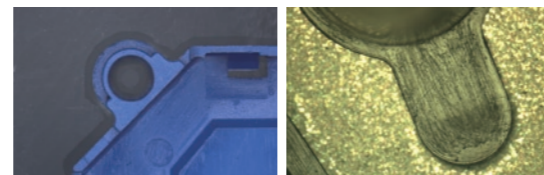

Plastic molded part Plastic molded part

Model	iNEXIV VMA-2520	iNEXIV VMA-4540	iNEXIV VMA-6555
XYZ strokes	250×200×200 mm	450×400×200 mm	650×550×200 mm
Maximum sample weight	15 kg (Accuracy guaranteed: 5 kg)	40 kg (Accuracy guaranteed: 20 kg)	50 kg (Accuracy guaranteed: 30 kg)
Maximum permissible error (L: Length in mm)	EUX, MPE: $2 + 8L / 1000 \mu\text{m}$ EUY, MPE: $3 + 8L / 1000 \mu\text{m}$ EUZ, MPE: $3 + L / 50 \mu\text{m}$	EUX, MPE: $2 + 6L / 1000 \mu\text{m}$ EUY, MPE: $2 + 6L / 1000 \mu\text{m}$ EUZ, MPE: $3 + L / 100 \mu\text{m}$	EUX, MPE: $1.2 + 4L / 1000 \mu\text{m}$ EUY, MPE: $2.0 + 4L / 1000 \mu\text{m}$ EUZ, MPE: $1 + L / 1000 \mu\text{m}$

Confocal model VMF-K



VMF-K3040

- **Supports samples with high contrast and unstable light reflection**

Accurate measurement of high contrast samples tends to be difficult with brightfield illumination because their edges appear unclear. Confocal optics provide a clear display, and facilitate accurate detection of sample edges.

High Contrast Sample (copper wire on print board)

Confocal observation accurately captures the shape, even for samples that are difficult to measure accurately in brightfield, due to effects such as halation.

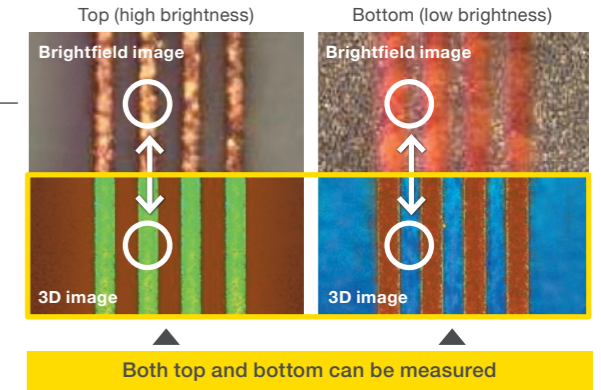

Top (high brightness) Bottom (low brightness)
Brightfield image Brightfield image
3D image 3D image
Both top and bottom can be measured

Applications

Micro wiring patterns (top and bottom), bonding wires, probe cards, WLP, PLP, etc.

Fine Bump and Substrate Pattern

A combination of 2D measurement with 15x zoom brightfield image and height measurement with 3D image enables diverse measurements.

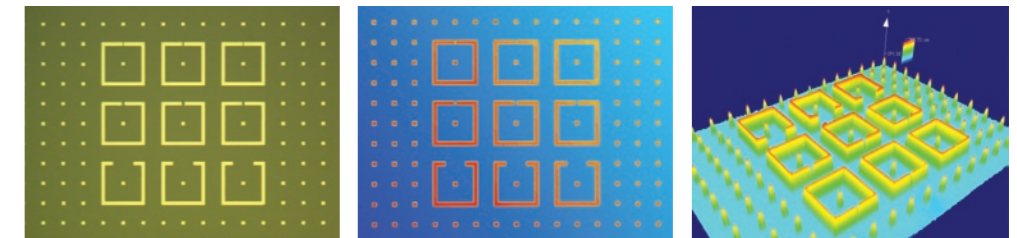

Brightfield image (minimum magnification) 3D image Bird's-eye view image by EDF/ Stitching Express (optional)

Bonding Wire Loop Height

The 3D image detects the highest points of all wires within the field of view at once. The wire shape can also be confirmed from the height profile information.

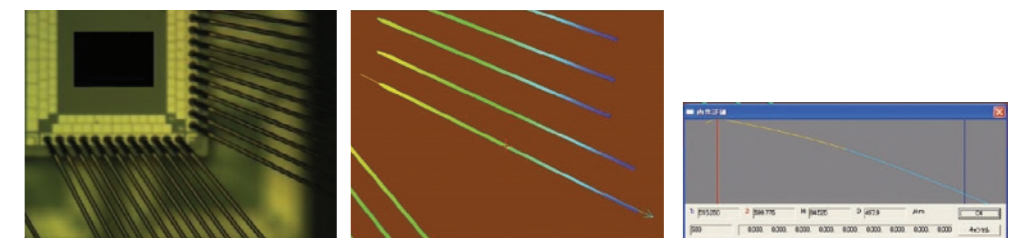

Brightfield image 3D image Display of wire height profile

Model	VMF-K3040	VMF-K6555
XYZ strokes	300×400×150 mm	650×550×150 mm
Zoom magnification (Type-S)	1.5x / 3.0x / 7.5x	
Zoom magnification (Type-H)	15x / 30x	
Zoom magnification (45x High-magnification head)	45x	
Maximum sample weight	20 kg	30 kg
Maximum permissible error (L: Length in mm)	EUX, MPE: $1.2 + 4L / 1000 \mu\text{m}$ EUY, MPE: $2.0 + 4L / 1000 \mu\text{m}$ EUZ, MPE: $1 + L / 1000 \mu\text{m}$	

Specifications

Model	VMZ-S3020	VMZ-S4540	VMZ-S6555
XYZ strokes	300×200×200 mm	450×400×200 mm	650×550×200 mm
Type TZ with low magnification lens	250×200×200 mm	400×400×200 mm	600×550×200 mm
Minimum readout	0.01 μm		
Maximum sample weight	20 kg (Accuracy guaranteed: 5 kg)	40 kg (Accuracy guaranteed: 20 kg)	50 kg (Accuracy guaranteed: 30 kg)
Maximum permissible error (L: Length in mm)	Eux, MPE Euy, MPE: 1.2 + 4L / 1000 μm / Euxy, MPE: 2.0 + 4L / 1000 μm / Euz, MPE: 1.2 + 5L / 1000 μm Probing error ^{1),2)} : MPE P _{F2D} 0.8 μm / Probing error of the imaging probe ^{1),2)} : MPE P _{FV2D} 0.3 μm		
Camera	Black and White / Color 1/3 CMOS Camera		
Working distance	Type 1, 2 and 3: 50 mm Type TZ: 11 mm	Type 4: 30 mm Type A: 73.5 mm (63 mm with Laser AF)	
Autofocus	Laser AF (Option for Type A) / Image AF		
Laser AF repeatability range ^{1),3)}	2σ ≤ 0.5 μm		
Illumination	Type 1, 2, 3, and 4: Episcopic, diascopic, and 8-segment ring with 3 angles *All white LED/Type 4 has only 1 angle Type TZ: Left objective lens: Episcopic, darkfield ; Right objective lens: Episcopic, diascopic, darkfield Type A: Episcopic, diascopic, and 8-segment ring with 1 angle *All white LED		
Power source, Power consumption	AC100 V-240 V, 50/60 Hz / 4 A – 2 A		
Dimensions (W×D×H) & weight	700×730×1793 mm / approx. 265 kg	1000×1340×1818 mm / approx. 510 kg	1200×1640×1818 mm / approx. 740 kg
	Controller: 190×450×450 mm / approx. 12 kg		
Footprint (W×D)	2700×2400 mm	3000×3000 mm	3200×3300 mm

- 1) Determined by Nikon in-house measurement method.
- 2) With Type 2 head, 15×
- 3) Workpiece: Chrome on calibration plate, without Type A head.
- 4) Includes maintenance space.

Overview of the
VMZ-S Series (video) ▶



Nikon Corporation Industrial Solutions Business Unit is certified as an ISO/IEC 17025 accredited calibration laboratory for video measuring systems by the IA Japan (International Accreditation Japan) as Accreditation No. JCSS0241.

ISO/IEC 17025: International standard, which specifies the general requirements to ensure that a laboratory is competent to carry out specific tests and/or calibrations

Date of initial accreditation:	November 22, 2010
Scope of accreditation:	Coordinate measuring instruments
Accredited section:	Industrial Solutions Business Unit
Calibration site:	Customer's laboratory (field service)
Calibration and Measurement Capability (CMC), (K=2, Level of Confidence Approximately 95%) [L=measurement length (mm)]	L ≤ 420 mm: 0.32 μm 420 ≤ L ≤ 1000 mm : (0.29 + 0.64 × L/1000) μm

Specifications and equipment are subject to change without any notice or obligation on the part of the manufacturer. March 2025 ©2021-2025 NIKON CORPORATION
N.B. Export of the products* in this catalog is controlled under the Japanese Foreign Exchange and Foreign Trade Law. Appropriate export procedures shall be required in case of export from Japan.
*Products: Hardware and its technical information (including software)
Company names and product names appearing in this brochure are their registered trademarks or trademarks.



WARNING TO ENSURE CORRECT USAGE, READ THE CORRESPONDING MANUALS CAREFULLY BEFORE USING THE EQUIPMENT.



NIKON CORPORATION
1-5-20, Nishioji, Shinagawa-ku, Tokyo 140-8601, Japan
Tel: +81 3 6743 5742
<https://industry.nikon.com/>

ISO 14001 Certified
for NIKON CORPORATION

ISO 9001 Certified
for NIKON CORPORATION
Industrial Solutions Business Unit

NIKON METROLOGY EUROPE NV
Interleuvenlaan 86, 3001 Leuven, Belgium
Tel: +32 16 74 01 01
Sales.NM@nikon.com

NIKON METROLOGY UK LTD.
UNITED KINGDOM Tel: +44 1332 811 349
Sales.UK.NM@nikon.com

NIKON METROLOGY SARL
FRANCE Tel: +33 1-60 86 09 76
Sales.France.NM@nikon.com

NIKON METROLOGY GMBH
GERMANY Tel: +49 211 4544 6951
Sales.Germany.NM@nikon.com

NIKON METROLOGY, INC.
12701 Grand River Road, Brighton, MI 48116 U.S.A.
Tel: +1 810 220 4360
Sales.NM-US@nikon.com

NIKON METROLOGY - MEXICO
Sales.NM-US@nikon.com

NIKON PRECISION (SHANGHAI) CO., LTD.
CHINA Tel: +86 21 6841 2050 (Shanghai)
CHINA Tel: +86 10 5831 2028 (Beijing branch)
CHINA Tel: +86 20 3882 0551 (Guangzhou branch)
Web.Nis@nikon.com

NIKON INSTRUMENTS KOREA CO., LTD.
KOREA Tel: +82 2 6288 1900
NIK.Sales@nikon.com

NIKON SINGAPORE PTE LTD.
SINGAPORE Tel: +65 6559 3651
NSG.Industrial-sales@nikon.com

PT. NIKON INDONESIA
INDONESIA Tel: +62 213 873 5005
PTN.Instruments@nikon.com
NIKON SALES (THAILAND) CO., LTD.
THAILAND Tel: +66 2633 5100
NST.Inst@nikon.com